

ALLCUT

Operating Instructions for ALLCUT HoleMatic 28/50



Hole Matic

THANKS FOR PURCHASING ALLCUT MAGNETIC DRILL MACHINE

GENERAL INSTRUCTIONS

TABLE OF CONTENT

General instructions.....	2
Machine overview.....	3
Safety measures.....	4
Before using for the first time.....	5
Preparing.....	6
Starting on the machine	7
Using the machine.....	7
Removing blockages.....	9
Cleaning.....	9
Maintenance.....	9
Storage.....	10
Technical data.....	10
Spare part list	11
Wiring drawing	12
Accessories	13

INTENDED USE

The ALLCUT Hole Matic 28/50 magnetic drilling machine is uniquely designed to be used for drilling operations using twist drills and annular cutters on magnetic metals, for cutting threads, and reaming within the limits specified in the technical data.

Any other use of the machine except stated above is inappropriate.



WARNING

Danger resulting from improper use

If the machine is not used as stated above, and if used in any other way, the machine may become a source of danger.

- Use the machine as described in the operating manual.

DEAR CUSTOMER,

Please read the instruction regarding the startup, safety, cleaning, and other details mentioned in this operating manual. Ignoring this may cause serious injury to the operator as well as the machine.

Keep this instruction manual for future use.

The manufacturer is not responsible for damage of the machine or accident caused due to not reading this instruction manual properly, using the machine other than its purpose, third party repair, modifying the machine without our consent or using of unauthorized spare parts, tools and accessories.

MACHINE OVERVIEW

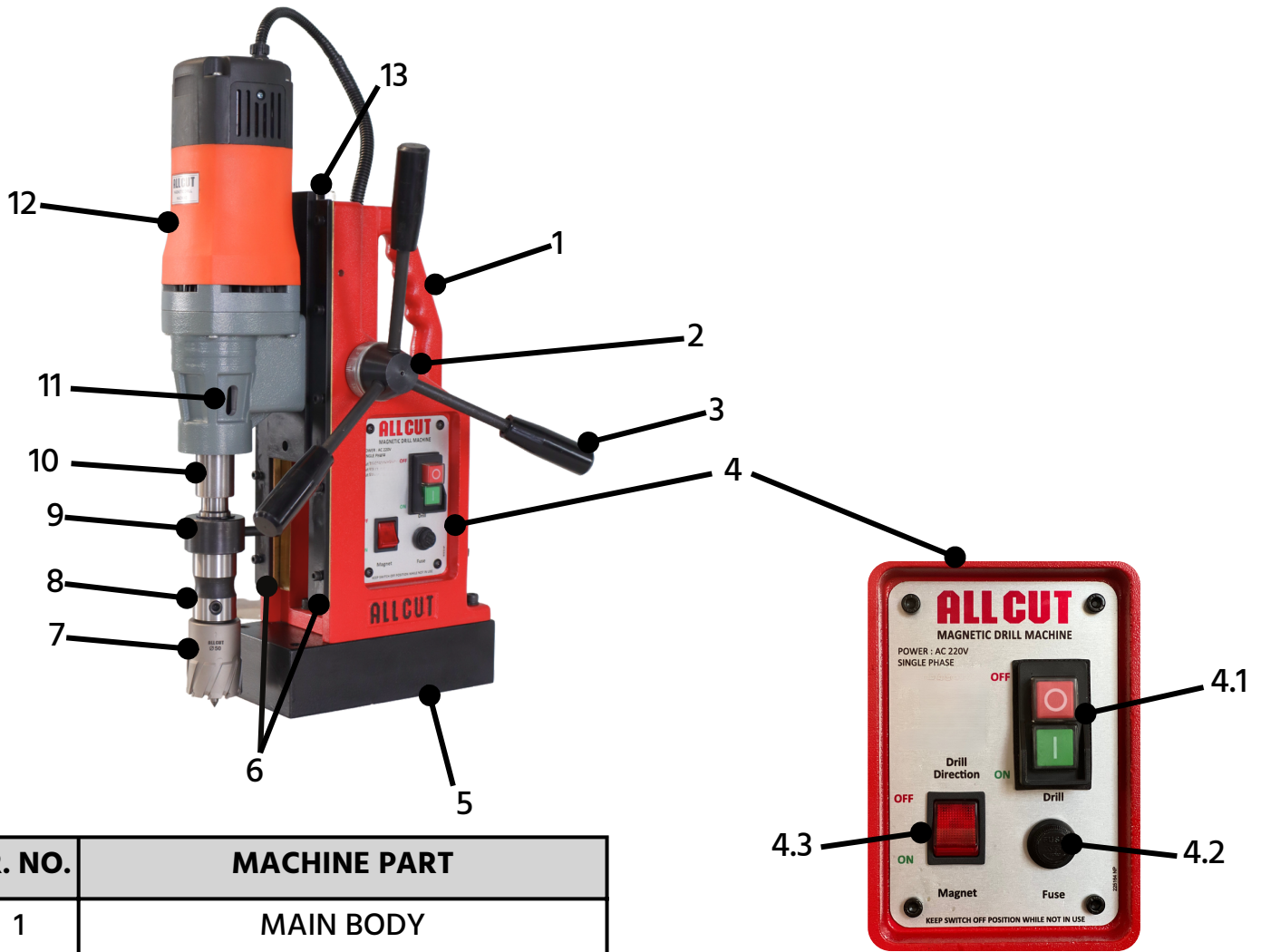

SR. NO.	MACHINE PART
1	MAIN BODY
2	PINION
3	HANDLE
4	PANEL
5	ELECTROMAGNET
6	STEEL WEDGES
7	ANNULAR CUTTER (TCT)
8	CUTTER ADAPTER
9	COOLANT BRACKET
10	SPINDLE WITH MT-3 SHANK
11	OPENING FOR EJECTOR PIN
12	DRILL MOTOR
13	STEEL SLIDE

SR. NO.	PANEL
4.1	MOTOR ON/OFF SWITCH
4.2	FUSE HOLDER
4.3	MAGNET ON/OFF SWITCH

SAFETY MEASURES

NOTE

When using electrical tools, please read and follow the following precautions to prevent any type of injury, fire or electric shock.

BASIC SAFETY MEASURES

- Do not use the machine on or near flammable environment.
- Person with heart diseases or medical conditions should use the machine under supervision or prevent using the machine.
- Person who is unable to operate the machine safely, should use it under supervision of a responsible person.
- Children are not allowed to use the machine.
- Before using the machine, check for any visible damages. Do not operate a damaged machine.
- Before beginning the work, check the condition of the safety chain and the function of the switches on the machine.
- Repairing of the connecting cables should be performed by a qualified electrician.
- Repairs of the machine should be carried out by an approved specialist workshop or by the manufacturer. Unapproved repairs can lead to considerable damage to the operator.
- Repairs to the machine during the guarantee period can only be performed by the manufacturer, otherwise the guarantee is invalid.
- Damaged parts should be replaced by original spare parts. This ensures the safety of the machine.
- Keep an eye on the machine during the operation.
- Store the machine in a dry environment.
- Make sure the machine is cleaned and free of metal chips after every operation .
- Do not expose the machine to moisture environment.
- Do not exceed the capacity of the machine. Refer to the technical data for the information.
- Keep the machine clean, dry and free of oil and grease.

WARNING

Risk of accident due to starting of the motor unintentionally!

Pay attention to the following measures to avoid injuries due to starting of the motor unintentionally.

- Press the red button (O) of the motor switch(4.1) after every operation.
- Switch off the machine with magnet switch (4.3) so the motor doesn't start.

DANGER

Danger from electric current!

Contact with live wires or components may lead to serious injury to the operator.

Read the following safety precaution to avoid any electric shock.

- Make sure the machine and main plug is beyond the reach of water or any other liquid.
- Do not operate the machine with panel or motor housing opened.
- If using extension cable, make sure the extended wire is of 1.5 mm².
- Check the condition of the extension wire regularly and replace it if damaged.

WARNING

Risk of injury due to improper handling of the machine!

Pay attention to these instructions in order to avoid any type of injury.

- Operate the machine with the protective equipment mentioned below.
- Do not wear protective gloves when the machine is on. The rotating part may catch the glove and torn off the hand.

ATTENTION

Potential damage to the machine due to improper use.

Read these instructions to avoid damage to the machine.

- Always carry the machine with the handle.
- Before plugging on the machine, check whether the voltage supply is proper (refer to the technical data sheet).
- Do not pull the main cable to remove the plug from the main socket.

REMEMBER THIS SYMBOLS



1



2



3



4



5

MEANING OF THE SYMBOLS:

1. Wear protective goggles.
2. Wear proper hearing protection equipment.
3. Do not put your hand near cutting area
4. Beware of electric shock.
5. Beware of rotating parts machine parts.



ALWAYS READ THIS MANUAL
BEFORE OPERATING THE MACHINE.

SAFETY MEASURES, BEFORE USING FOR THE FIRST TIME

WARNING

- Always switch off the machine when changing tool, conducting maintenance or cleaning. Wait till the machine has completely stopped to avoid unintentional starting of the machine.
- Do not put your hand into the machine while the machine is in operation. Remove the metal chips only when the machine is standstill. Wear the protective gloves when removing metal chips.
- When using a temporary plate for drilling, make sure the supplied voltage is stable. For more safety, use a safety belt so the machine holds the plate securely.
- Secure the machine with a safety chain when working in an inclined or vertical position and during overhead operation. The machine could fall down if the magnet is loosened or the power drops.
- Check that the tool is securely tightened before using.
- Do not allow the connecting cable to hang over the edges.

ATTENTION

- Do not crush the power cord.
- Do not put the main power cord near heated objects or chemical liquids.
- Do not drag the power cord across sharp edges or hot surfaces.
- Put the power cord in such a way that it cannot be caught by rotating parts of the machine.
- The machine stops automatically when the magnet switch (4.3) is switched off.

NOTE

Check for any visible signs of damage or missing items on delivery. Report an incomplete or damaged delivery to your dealer/supplier/manufacturer.

Preparation

Read the following instructions carefully and take the safety precautions before starting the machine.

Additional safety measures for special jobs.

Drilling Vertically

WARNING

Risk of injury due to machine falling down.

- When working on inclined or vertical position or overhead position, the machine should be secured with a safety chain to prevent it from falling.
- Tighten the safety chain as much as possible around the handle of the machine.
- Check the secure fitting of the safety of the safety chain before starting the work.
- Use proper protection equipment as mentioned on the machine.

Additional safety measures for special jobs.

Drilling using temporary plate

WARNING

When working of the machine is on scaffolding, the machine can make sudden vibrations and could slip off the plate, causing danger. Prevent these by:

- Securing the machine with the plate using the safety chain.
- Clamping the plate tightly with the surface that is to be drilled.
- Wear proper safety equipment.

NOTE

- Make sure to make a pilot punch before drilling.
- Always use cutting oil or coolant when drilling.

Check the condition of the surface

The magnetic force is dependent on the condition of the surface/plate to be drilled. If the surface/plate is painted, coated, uneven or rusted, the magnetic force will be reduced.

To increase the magnetic force of the electromagnet, the surface/plate should be:

- The plate should be magnetic.
- the electromagnet (5) should be free from grease, oil, metal chips, or any other dirt.
- The plate should be smooth and levelled.

The electromagnet best works with low-carbon steel surface with a thickness of at least 20mm.

Plate with low thickness

When drilling into low thickness steel plate, we recommend to use an additional steel plate with 200X200X20 mm dimensions. Secure the additional plate tightly with the surface to prevent it from falling.

Inserting the tool

The machine is equipped with MT-3 shank. USE ONLY TOOLS WITH MT-3 SHANK ON THE MACHINE.

WARNING

Risk of injury!

- Do not use damaged, spoiled or worn out tools.
- Change the tools only when the machine is switched off and at standstill.
- After inserting, make sure the tool is engaged tightly.
- Only use the tools that are compactible with the machine.

INSERTING THE TOOLS

- Before fitting the tool, make sure to clean the shank and the tool.
- Insert the tool into the spindle taper (10) of the machine from below.

REMOVING THE TOOLS

- Turn the tool until the ejector pin slips into the opening for ejector pin (11).
- Loosen the tool by tapping on the ejector pin with a hammer.

USING THE MACHINE WITH ANNULAR CUTTERS.

INSERTING THE CUTTER

- First remove the tool, if any, from the spindle taper (10) using ejector pin.
- Insert the cutter adapter (8) provided into the spindle taper (10).
- Insert the cutter with the pilot pin into the Weldon shank of the adaptor.
- Tighten the grub screws of the Weldon shank.

REMOVING THE CUTTER

- Untighten the grub screws using the Allen key and remove the cutter from below.
- Remove the cutter adapter using ejector pin.

ATTENTION

Risk of injury!

- Do not use damaged, spoiled or worn out cutters.
- Insert or remove the adapter only when the machine is switched off and at standstill.
- Make sure the adapter is engaged tightly.
- Make sure that the rod of coolant bracket (9), is between the steel wedges (6).
- Make sure that the grub screws of the Weldon shank is properly aligned with the flat surface of the cutter.
- Assure that the grub screws are tightened properly.
- Refer to the figure below.

WARNING

Risk of injury!

- If the cutter is not aligned properly, the cutter will come out of the shank during the operation, causing injury to the operator.
- Starting on the machine with unaligned cutter will break the cutter in between the operation.

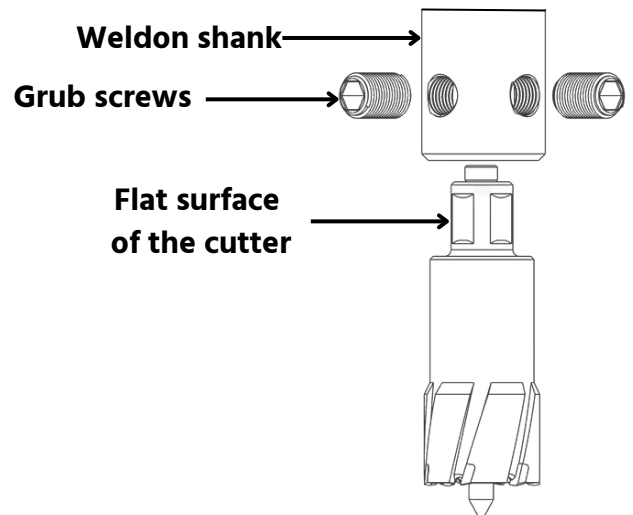

STARTING ON THE MACHINE, USING THE MACHINE

Switching the machine ON/OFF

- First turn on the magnet switch (4.3).
- Then turn ON the machine with the green button (I) on the drill switch (4.1).

NOTE

- The machine can only be turned on when the electromagnet is active or turned on.

Drilling with the machine

NOTE

The ALLCUT Hole Matic 28/50 is designed to be used with drill with twist drills, annular cutters, to make threads and reaming purposes. Read these instructions to proceed for your purposes of using of the machine.

Drilling with twist drills

When drilling with twist drills, proceed as follows:

- Push the twist drill with MT-3 taper shank into the spindle taper (10) from below.
- Position and fix the machine at the location of the use.
- Switch ON the electromagnet by switching ON the magnet switch (4.3).
- Switch ON the drill switch (4.1) by pressing the green button (I).
- Direct the drill to the surface/plate by pulling down the handle (3).



ATTENTION

Observe the following instructions when drilling with twist drill:

- Under excessive pressure, the drill can wear out and the machine can be overloaded.
- Make sure to remove the metal chips regularly, especially when with higher drilling depths.
- USE PROPER CUTTING OIL OR COOLANT FOR LONGER TOOL LIFE.
- Follow proper drilling direction.

Drilling with Annular cutter

The cutter adaptor of the ALLCUT Hole Matic 28/50 is equipped with internal cooling system for the annular cutter. Always cool down the tool while drilling for better cutter life.

Turning ON the cooling system

To turn on the cooling system, proceed as follows:

- Attach the coolant bottle provided, on the machine.
- Connect the tube of the coolant bottle to the brass nipple on coolant bracket (9) on cutter adapter, by pushing the tube into the nipple.
- Fill up the coolant bottle with coolant or lubricating oil and screw on the bottle cap.
- Turn on the cock on the coolant bottle and let the coolant pass through the tube.

NOTE

- If the coolant doesn't pass the tube easily, loosen the bottle cap a little bit. Let the air in the bottle escape.
- Assure that the coolant or oil you are using is free of metal chips or any dirt, to prevent the wearing out of the tube.
- The coolant will come out from the bottom of the cutter adapter (8), cooling the cutter directly.
- The cooling system will only work when you use the cutter with proper pilot pin.
- Use the pilot pin for every operation. It assure proper rotation of the cutter and enables the cooling system.
- The cooling system will not work when drilling in overhead position.

When drilling with core drills, proceed as follows:

- Insert the appropriate pilot pin into the annular cutter and insert the cutter into the cutter adapter from below (8).
- Align the cutter and tighten the grub screws of the Weldon shank.
- Put the machine on the surface to be drilled on.
- Switch ON (4.3) the magnet switch to enable the electromagnet. Check that the machine sticks to the plate properly.
- Switch ON the machine by pressing the green button (I) on the drill switch (4.1).
- Slowly feed the handle (3) without exerting much pressure, directing the cutter to the material to be drilled on.



ATTENTION

Observe the following instructions when drilling with annular cutter:

- Drilling with annular cutters does not require much pressure.
- Do not apply too much pressure on the cutter. Doing so will reduce the cutter life, or even break the cutter. And also the machine will be overloaded.
- Always use high performance coolant for better drilling.
- Make sure to remove the metal chips regularly, so that the metal chips do not come in the way of the cutter while cutting.

Reaming with the machine

The ALLCUT Hole Matic 28/50 is a multi-purpose magnetic drill machine, that can also be used for reaming purpose.



ATTENTION

- When reaming with the machine, look out for the limits stated in the technical data.
- Reamers with MT-3 taper shank should only be used with the machine.
- Always use proper cutting oil or coolant while reaming with the machine.

REMOVING BLOCKAGES, CLEANING, MAINTENANCE

Removing blockages

WARNING

Risk of injury due to broken tool or metal chips.

- Always use protective gloves when using the machine.

Blockages caused by broken tool:

- Switch OFF (4.1) the machine and remove the plug from the main socket.
- Move the machine slide up with the help of the handle (3).
- Remove the metal chips and replace the broken tools.

Other blockages:

- Switch OFF the drill motor (4.1). Let the electromagnet be on.
- Move the machine slide up with the help of the handle (3).
- Remove the metal chips and check for the tool damage.

NOTE

- Always use good quality drill bits and cutters for better performance.
- Do not use damaged or worn out drill bits and cutters.
- Do not exert more pressure on the handle (3), if the drill bit or cutter is worn out or damaged. Doing so will damage the machine.

WARNING

Always remove the slug from the cutter after every operation.

- The pilot pin attached to the cutter removes the slug from the cutter automatically.
- But always make sure that the slug is always removed from the cutter.
- DO NOT hammer the cutter if the slug is not ejected.
- If the slug is stuck, take a punch and slightly hammer that punch, to remove the slug without damaging the cutter (Refer to the figure below).

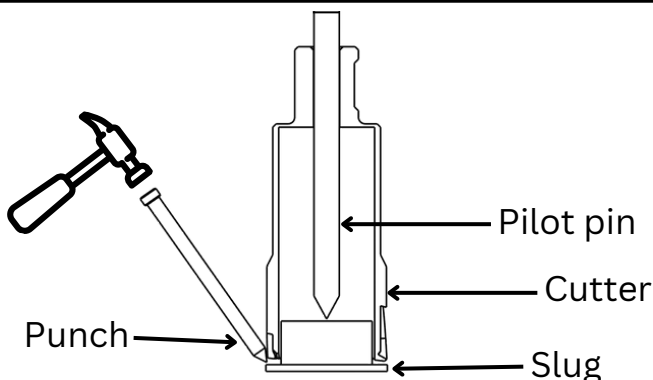

Cleaning the machine

WARNING

- Make sure to switch OFF (4.3) completely and remove the main cord from the main socket.
- When using compressed air for cleaning or removing metal chips, wear the protective goggles and gloves for safety. Protect other persons in the working area too.

ATTENTION

- Never use water to clean the electric panel or electric components.
- Prevent the machine from water or other liquids.

After each use:

- Remove the inserted drill bit or tool.
- Remove the metal chips and coolant residues.
- Clean the tool and the spindle taper (10) on the machine.
- Clean the machine slide (13) with clean cloth.
- Clean the electromagnet (5) base and let it be free of oil, metal chips or dirt.
- Clean the whole machine and remove all the dirt and grease.

Maintenance

WARNING

Danger Caused by unqualified repairs !

Unqualified or third-party repairs leads to serious damage for the operator and the machine too.

- Repairs of electrical components should only be carried out by the manufacturer or by skilled person.

Adjusting the machine slide:

If the machine slide (13) slips down easily, it must be adjusting. To do this, proceed as follows:

- Take the M5 Allen key provided with the tools kit.
- Look out for hex bolts on steel wedges (6).
- Tighten the hex bolts a little bit and check the slide.
- If the slide is too tight loosen the bolts.

Replacing the carbon brushes

Check out for the worn out carbon brushes. Replace the carbon brushes if needed. Unauthorized carbon brushes will damage the drill motor (12).

STORAGE, TECHNICAL DATA

Customer service/service

If the machine is too damaged or cannot be repaired by you, please contact ALLCUT team/dealer/supplier. We will be happy to provide you with best service.

Storage

If you are not planning to use for a long time, clean the machine as described in the CLEANING SECTION. Store the machine and all its accessories in a dry, clean and non-moisture environment, to prevent it from rusting.

Technical data

Model	ALLCUT 28/50	
Dimensions (L X W X H)	335 X 190 X 480	mm
Electromagnet (L X W X H)	230 X 115 X 60	mm
Weight	28	kg
Power supply	220 V single phase	
Motor W	1500	W
Noise emission	90	db
Drilling depth:		
Twist drill (∅):	200	mm
Annular cutter (∅):	50/75/100	mm
Drilling capacity:		
Twist drill (∅):	28	mm
Annular cutter (∅):	50	mm
Tapping capacity	No	
Reaming capacity (∅):	28	mm
Speed range (NO-Load)	640	rpm
Reverse/forward	No	
Spindle taper	MT-3	
Main cord length	2	m

NOTE

The speed range described in technical data is NO-LOAD speed. the speed may vary at the time drilling by 20%.

SAFETY FIRST

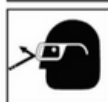

Always wear eye protection while using cutting tools, or in the vicinity of cutting.



CAUTION! Cutters are sharp. Wear gloves when installing or removing cutter from arbor. Do not grab a rotating cutter.



CAUTION! The slug is ejected at the end of the cut. Do not aim cutter or arbor so that ejected slug may hit someone around, or below you.



CAUTION! To prevent electric shock, do not use power tools near wet areas, or where power tool may become wet.

SPARE PARTS LIST

Motor Parts

Stand Parts

NO	NAME	PART CODE
3	Housing Cap	55A003
4	Brush Holder	55A004
5	Carbon Brush	55A005
7	Motor Housing	55A007
8	Field Coil	55A008
9	Fan Guide	55A009
10	Bearing Cap	55A010
11	Armature Bearing	55A011
12	Armature	55A012
13	Armature Bearing	55A013
14	Bearing Plate	55A014
15	Bearing	55A015
16	Bearing	55A016
17	Main Gear	55A017
18	Bearing for Gear	55A018
19	Spindle Gear	55A019
20	Oil Seal	55A020
21	GEAR BOX Bearing	55A021
22	Gear Box	55A022
23	Oil Seal	55A023
24	Spindle Bearing	55A024
25	Main Spindle	55A025
28	Coolant Bottle	55A028
29	Grub Screw	55A029

NO	NAME	PART CODE
1	MAIN BODY	AS5501
2	ELECTRO MAGNET	AS5502
3	MAIN SLIDE	AS5503
4	RACK	AS5504
5	PINION	AS5505
6	HANDLE	AS5506
7	PANEL COMPLETE	AS5507
7A	SWITCH	AS5507A
7B	RECTIFIRE	AS5507B
7C	DIRECTION SWITCH	AS5507C
7D	PANEL PLATE	AS5507D
7E	FUSE HOLDER	AS5507E
8	METAL WEDGE	AS5508
9	STEEL WEDGE	AS5509
13	COOLANT BOTTLE	AS5512

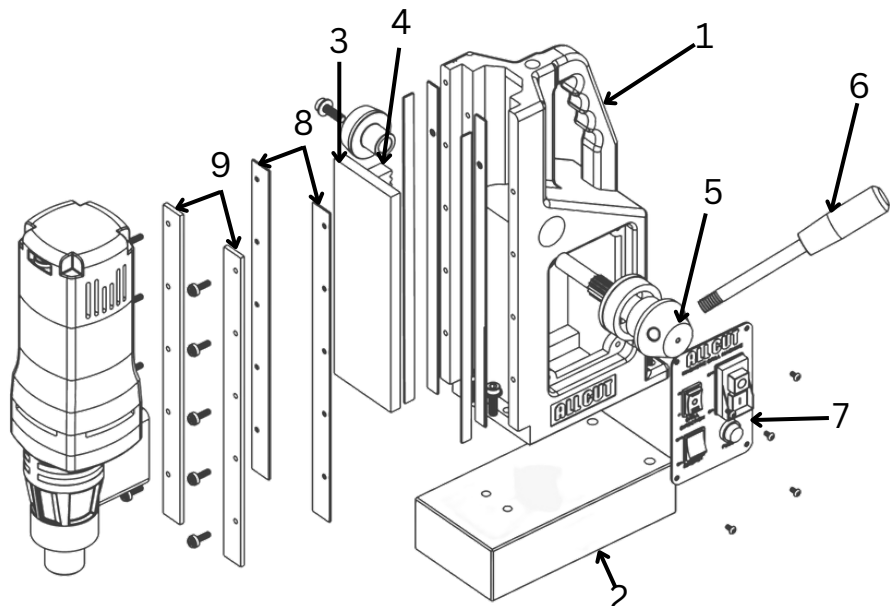
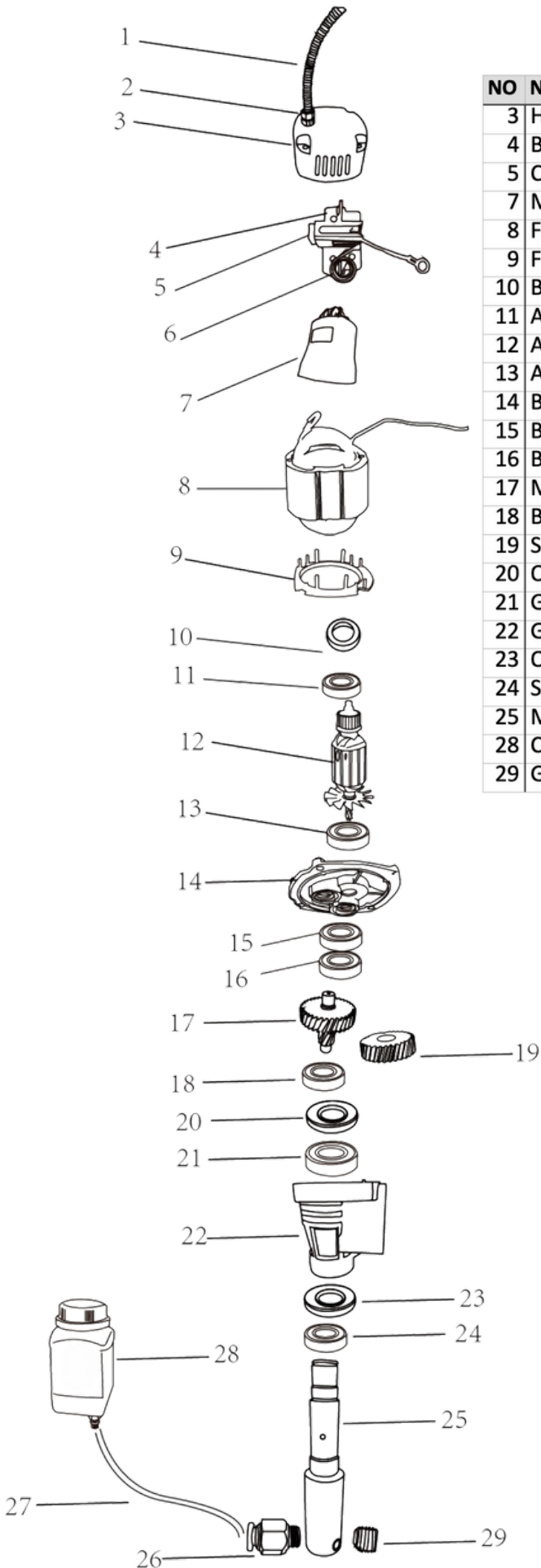

WIRING DRAWING

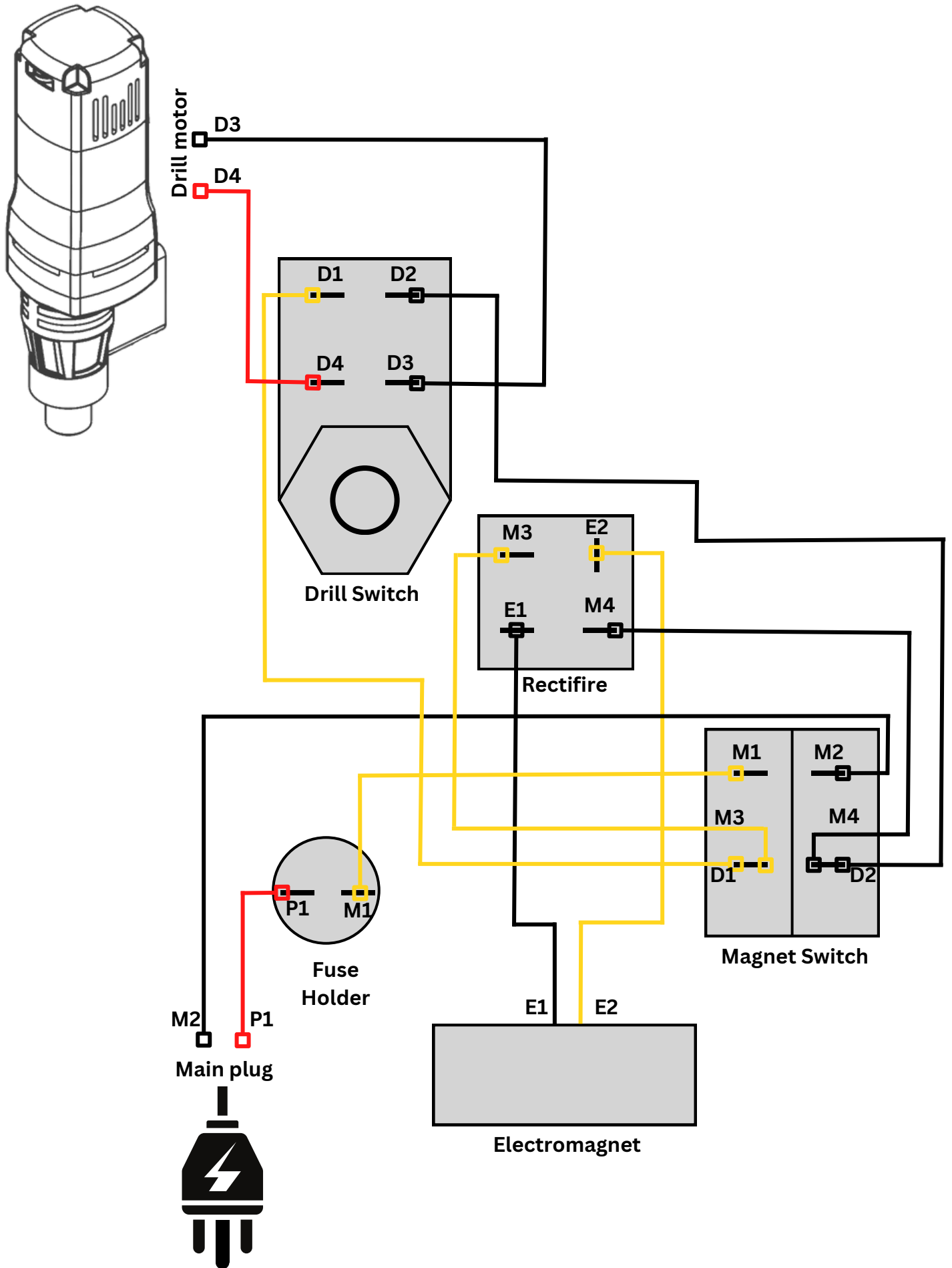

ACCESSORIES

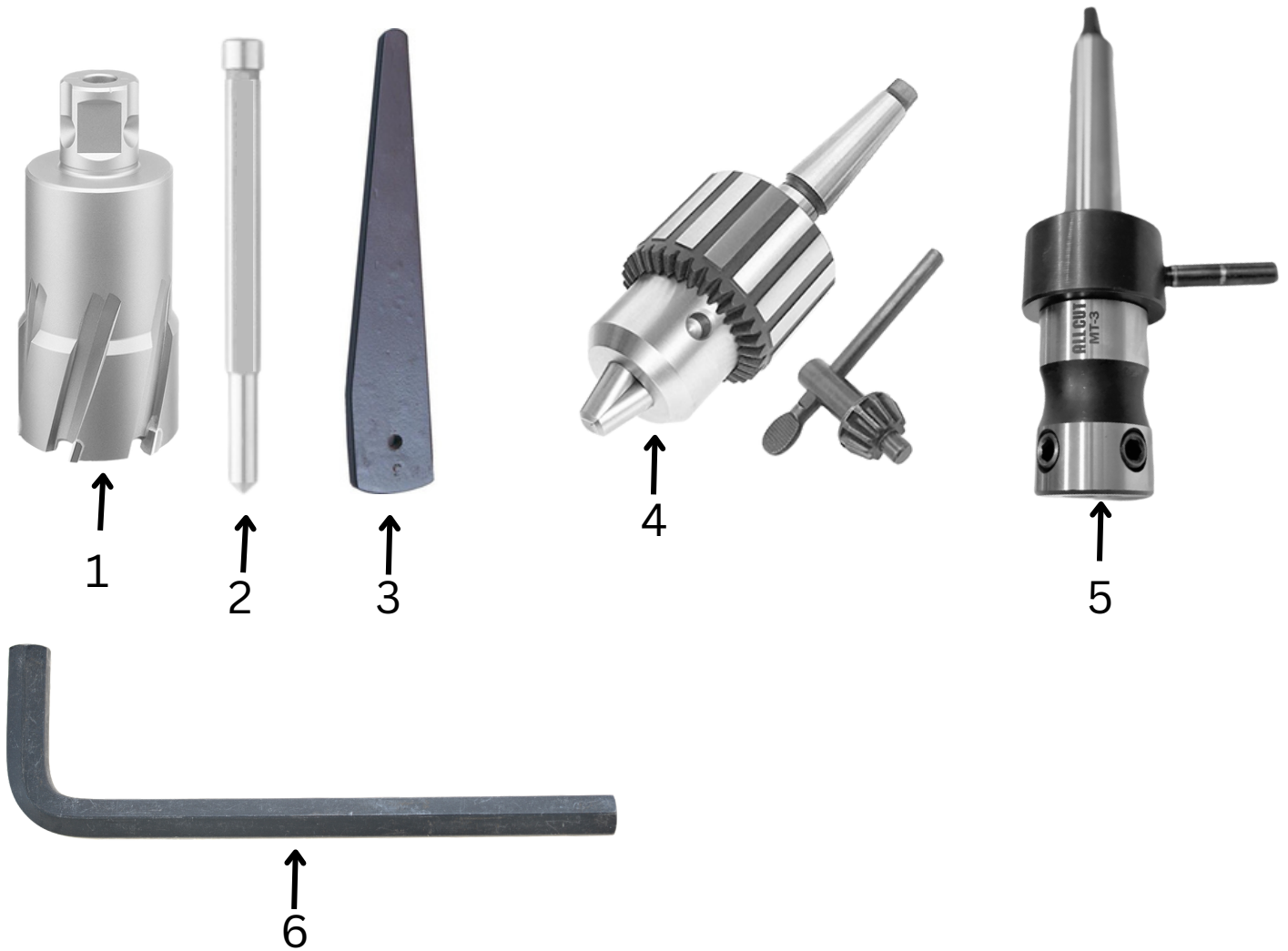

SR. NO.	ACCESSORIES	
1	ANNULAR CUTTER (HSS/TCT)	AAC (ALL SIZES)
2	PILOT PIN	AAC
3	EJECTOR PIN	INC
4	DRILL CHUCK ARBOR	AAC
5	CUTTER ADAPTER	INC
6	ALLENN WRENCHES	INC

NOTE
 The products which are marked with AAC are extra accessory and have to be paid for each of them.

(INC= INCLUDED) (AAC= AVAILABLE AS ACCESSORY)

ALLCUT[®]sales

 **www.allcut.in**

EXPERIENCE HAPPY AND SAFE DRILLING WITH ALLCUT MAG DRILLS